

Algorithms for Duty Cycle Control in Wireless Sensor Networks- A Survey

Jyothi T

Assistant Professor, Dept of Information Science & Engineering
GSSSIETW, Mysuru

Abstract— A Wireless Sensor Network contains a large amount of Sensor Nodes that are mainly data-centric. The sensor nodes operate on battery, they cooperate among themselves and transfer data to the sink which processes the sensed information. The nodes in sensor networks have limited battery power and it is not feasible or possible to recharge or replace the batteries, therefore power consumption should be minimized so that overall network lifetime will be increased. In order to minimize power consumed during idle listening, some nodes, which can be considered redundant, can be put to sleep. In this paper the scheduling algorithms S-MAC, MS-MAC, RMAC are considered and routing algorithms RACP & SIPF are compared. This paper presents the overview, strengths and limitations of the algorithms and makes comparative analysis of RACP and SIPF. The objective is to make observations about how the performance of these algorithms can be improved.

Keywords: Duty Cycle Control, SMAC, MSMAC, RACP, SIPF.

INTRODUCTION

Wireless sensor network (WSN) is widely considered as one of the most important technology which has received tremendous attention from both academia and industry all over the world. A WSN typically consists of a large number of low-cost, low-power, and multifunctional wireless sensor nodes, with sensing, wireless communications and computation capabilities [1, 2]. These sensor nodes communicate over short distance via a wireless medium and collaborate to accomplish a common task. The basic philosophy behind WSNs is that, while the capability of each individual sensor node is limited, the aggregate power of the entire network is sufficient for the required mission. The key challenge in wireless sensor network protocol designs is to provide energy efficient communication, since most of the nodes in sensor networks have limited battery power and it is not feasible to recharge or replace the batteries. There are several levels of power consumption in sensor networks such as:

- a. Idle Listening: The major power consumption source for WSNs
- b. Retransmissions resulting from collisions
- c. Control packet overhead
- d. Unnecessarily high transmitting power
- e. Sub-optimal utilization of the available resources.

By definition, sensor nodes are deployed in an ad hoc fashion, with individual nodes remaining largely inactive for long periods of time. In order to minimize power consumed during idle listening, some nodes, which can be considered redundant, can be put to sleep. Therefore the energy of the nodes and the energy of the network are conserved. The idea is sensor nodes dynamically create on-

off schedules such that the nodes will be awake only when they are needed. This also limits the collisions, therefore the energy consumed during retransmissions. Although, it seems best way to limit consumed energy and the main consideration should be energy efficiency, the other QoS issues have to be considered. The key design considerations for duty cycle control protocol design are scheduling and routing.

SCHEDULING

In order to maintain a connected network topology and to guarantee the delivery of the packets by scheduling the sleep schedules of the nodes between source and destination, the MAC layer protocols have to be carefully designed.

S-MAC

The S-MAC [3] protocol is proposed as a MAC algorithm in order to coordinate and synchronize the sleep/wakeup duty cycles. S-MAC is basically a CSMA/CA protocol based on 802.11. To maintain the synchronization, each node broadcasts its schedule in a SYNC message periodically, so that the neighbours can update that information in their schedule tables. The problem is, neighbours can never see each other, which can be caused by SYNC message corruption, interference, or medium kept busy and SYNC packets cannot be sent in time. It is overcome by periodically followed neighbour discoveries. The S-MAC does not require all nodes to be synchronized, only the nodes belonging to the same virtually constructed cluster have to be synchronized, however the border nodes have to maintain more than one schedule. The scheme works well with stationary network topologies in which frequent changes are not common.

MS-MAC

Most of the MAC protocols have been proposed for stationary networks. The objective of the following MAC protocol is its ability to work energy-efficiently in both stationary scenarios and mobile nodes. MS-MAC [4] would work similarly to S-MAC with stationary nodes. In order to avoid the excess waiting time of mobile nodes in order to join a new cluster, each node discovers the presence of mobility within its neighbourhood based on the received signal levels of periodical SYNC messages from its neighbours. If there is a change in a signal received from a neighbour, it presumes that the neighbour or it-self are moving, and predicts the level of the mobile's speed. The SYNC message in MS-MAC also includes information on the estimated speed of its mobile neighbour or mobility information. If there is more than one mobile neighbour,

then the SYNC message only includes the maximum estimated speed among all neighbours. This mobility information is used by neighbours to create an active zone around a mobile node when it moves from one cluster to another cluster, so that the mobile node can expedite connection setup with new neighbours before it loses all its neighbours.

RMAC

Du et al. [5] proposed the algorithm in order to reduce end-to-end latency with duty cycle MAC protocol. The nodes that are forwarding data has to be awake only when they are receiving or transmitting a packet. The protocol sends a small control frame along the data forwarding path in order to inform every node when to be awake in order to receive the packet.

There are three stages of an operational cycle; SYNC, DATA, and SLEEP. Fig. 1 shows an overview of the RMAC algorithm.

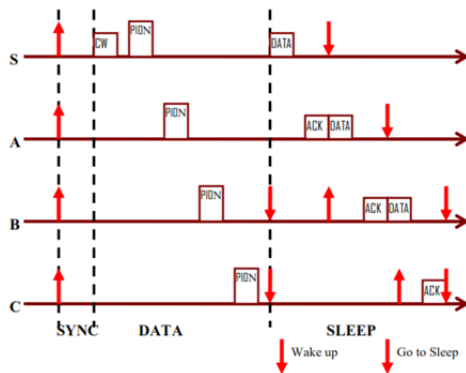

Fig. 1: RMAC Overview

In the SYNC stage, RMAC synchronizes the clocks on the sensor nodes. In the DATA stage, firstly a control frame is sent in order to initiate the traffic. PIONs namely a series of Pioneer frames are used as control frames like RTS and CTS. A PION is for requesting communication from downstream, like an RTS frame and also used for confirming the communication to upstream like CTS. Using a PION in dual purpose increases the efficiency. During the SLEEP period, nodes go to sleep if they do not have a communication task that is set by a PION. If they are stimulated with a PION, they must stay awake for a specific time in order to be able to receive and forward the packet. Completing its task, each node goes back to sleep state.

CROSS LAYER SCHEDULING ALGORITHM

The cross-layer scheduling algorithm for power efficiency [6] is proposed in order to conserve energy by turning off some sensor nodes. The idea is sensor nodes dynamically create on-off schedules such that the nodes will be awake only when they are needed. The scheduling and routing schemes work separately. There are two phases of the algorithm: The Setup and Reconfiguration Phase and the Steady State Phase.

The Setup and Reconfiguration Phase: It is initialization of the network to update the network routes and queries. This phase is relatively short; its goal is to set up the schedules that will be used during the steady state phase. The setup and reconfiguration algorithm is independent of the underlying routing algorithm. Therefore, many of the algorithms available for routing in ad hoc and sensor networks can be used. Power aware routing algorithms may be preferable, as they have been shown to provide substantial increases in network lifetime.

The Steady State Phase: It is similar to forwarding phase. It utilizes the Schedule established in the setup and reconfiguration phase to forward the data to the base station. Each node stores a schedule table. The scheduling for sleep and active states are calculated according to the packets that the nodes will transfer.

TOPOLOGY DISCOVERY ALGORITHM

A Topology Discovery Algorithm for Sensor Networks with Applications to Network Management [7] constructs the approximate topology of the network, using neighbourhood information and putting the redundant nodes to sleep. These nodes logically organize the network in the form of clusters comprised of nodes in their neighbourhood. TopDisc forms a Tree of Clusters (TreC) rooted at the monitoring node, which initiates the topology discovery process.

COMPARISON OF THE PROTOCOLS

Putting nodes to sleep affects network layer, because the sleeping nodes are no longer the part of the network, so they cannot participate in the routing. Moreover there will be topology changes caused by sleep schedules. A link between two nodes will be active if and only if both nodes are active. The path selection has to be carefully engineered, because the algorithm affects the latency and power consumption. The Table 1 gives comparison of the protocols and algorithms for duty cycle.

TABLE I: Comparison of Protocols & Algorithms

Routing Protocols	Sleep Decision
S-MAC	Predefined duty-cycle
MS-MAC	Predefined duty-cycle
RMAC	Synchronization using Pion packets
The Cross-Layer Scheduling Algorithm	Each node adjusts its duty cycle dynamically according to network load.
A Topology Discovery Algorithm	Each node decides to sleep according to the network topology, its location, and the residual energy

RACP

Liu and Hsin [8] proposed Role-Alternating, Coverage-Preserving, and Coordinated Sleep Algorithm (RACP) in order to put redundant nodes into the sleep (off) state so the idle listening power dissipation would be eliminated, the overall network power consumption would be decreased, and the network lifetime would be increased.

The algorithm can be considered as divided into cycles consisting of two phases. In the first phase each sensor informs its neighbours its location by sending the coordinate packet, COR. The COR packet is sent at the beginning of the each duty cycle periodically. At the same time, nodes listen to their neighbours' COR packet. In the next phase, the sensor decides to enter sleep state after realizing that its sensing area is fully embraced by its neighbours. The node deciding to sleep sends REQs to its neighbours. If the neighbours send ACK, they become sponsors for a designated time. The sponsors are not allowed to sleep for the designated time. The node sending requests decides to sleep if it receives enough ACKs, to fully cover its sensing area.

In order to avoid simultaneous sleep requests of neighbour nodes and ACKs, waiting a random back-off time before sending REQs and ACKs is proposed. The back-off time can be proportional to the residual energy in order to make easier to put sleep the nodes with low residual energy.

SIPF

Sink Initiated Path Formation (SIPF) for sensor network is a sleep scheduling algorithm in order to further increase the sleep sensor ratio and thus reduce overall energy consumption and increase network lifetime. The algorithm can be considered as divided into duty cycles consisting of two phases. Each cycle mainly consists of a self-scheduling phase and a data transfer phase.

In the self-scheduling phase, some nodes will be decided to be redundant and they can be put off. In the data transfer phase only necessary nodes will be awoken, and the data transfer is done from event to sink.

The self-scheduling phase is divided into three subsections. At the beginning of the first duty cycle, the roles for the deployed nodes are not assigned. Each node considered as knowing its coordinates, dimensions of the deployment region, and the coordinates of the sink. The deployed nodes decide to be a regular node or a leaf regular node according to their coordinates. The nodes on edges of the deployment area are considered as leaf regular nodes, the other nodes are regular nodes. The second sub phase is selection of head leaf nodes. The main idea is selecting the possible most distant neighbour node as the next node instead of making a random selection. The last sub-phase is the selection of central head nodes.

COMPARISON OF RCAP AND SIPF

RACP and SIPF is based on increasing number of sleeping sensors. The algorithms consists of cycles in which nodes decides to sleep or not. In each cycle, different nodes select to be awake. Therefore periodical sleeping is realized and increasing sleep sensor ratio increases network lifetime. SIPF outperforms RACP, in terms of the ratio of sleeping nodes in densely deployed sensor networks. This signifies reduced power consumption in a specific time with increased sensor network lifetime. This, however, is achieved at the cost of reduced area coverage.

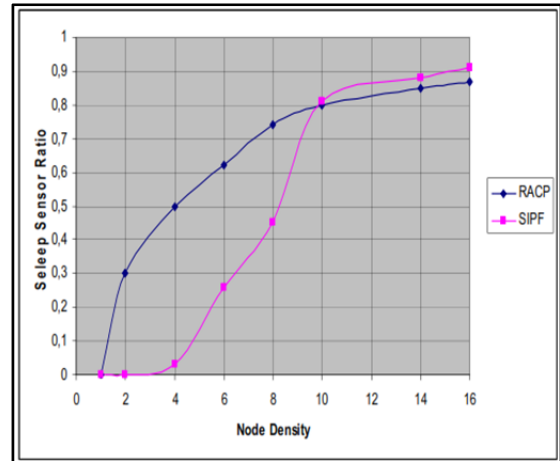

Fig. 2: Comparison of Performance

The drawback of SIPF can be overcome by combining SIPF with RACP.

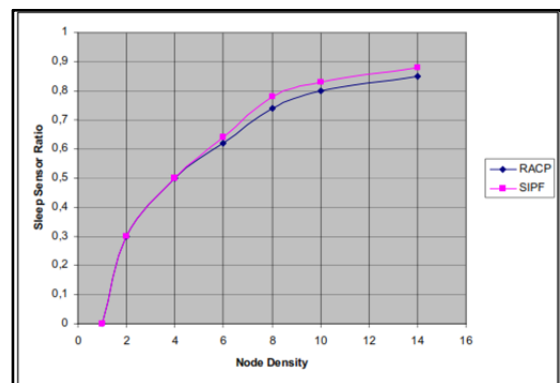

Fig. 3: Performance comparison of RACP with SIPF combined with RACP

PERFORMANCE PARAMETERS

The following metrics have been considered to perform the comparative study of the algorithms through simulation.

Sleep sensor ratio: defined as the ratio of the number of sleeping sensors to the number of total sensors averaged over time before the first sensor death.

Edge nodes: Nodes located at the boundary of the deployed area.

Coverage density: Density of nodes in the network coverage.

Power Consumption: The sensor node consumes power for sensing, communicating and data processing.

Network Lifetime Time until the first sensor node or group of sensor nodes in the network runs out of energy.

TABLE II: Comparison of Performance

	RCAP	SIPF
Sleep Sensor Ratio	Low	High
Edge nodes	Awake	Asleep
Coverage Density	High	Low
Power dissipation	High	Low
Network Lifetime	Low	High

CONCLUSION

One of the main challenges in the design of routing protocols for WSNs is energy efficiency due to the scarce energy resources of sensors. The energy consumption of the sensors is dominated by data transmission and reception. Therefore, routing protocols designed for WSNs should be as energy efficient as possible to prolong the lifetime of individual sensors, and hence the network lifetime. In this paper, scheduling and routing protocols are surveyed along with comparative analysis of RACP and SIFP algorithms. SIFP outperforms RACP in terms of sensor sleep ratio thereby reducing power consumption and increasing network lifetime. An important research goal for the future is to determine whether all these routing optimization algorithms can be unified under a single routing architecture that would be suitable for a large set of applications.

REFERENCES

- [1] S.K. Singh, M.P. Singh, and D.K. Singh, "A survey of Energy-Efficient Hierarchical Cluster-based Routing in Wireless Sensor Networks", International Journal of Advanced Networking and Application (IJANA), Sept.–Oct. 2010, vol. 02, issue 02, pp. 570–580.
- [2] S.K. Singh, M.P. Singh, and D.K. Singh, "Energy-efficient Homogeneous Clustering Algorithm for Wireless Sensor Network", International Journal of Wireless & Mobile Networks (IJWMN), Aug. 2010, vol. 2, no. 3, pp. 49-61
- [3] W. Ye, J. Heidemann, and D. Estrin, "An Energy-Efficient MAC Protocol for Wireless sensor Networks," in Proc. IEEE. INFOCOM, Jun. 2002
- [4] H. Pham and S. Jha, "An adaptive mobility-aware MAC protocol for sensor Networks (MS-MAC)", The 1st IEEE International Conference on Mobile Ad-hoc and Sensor Systems (MASS-2004), October 24-27, 2004, Fort Lauderdale, Florida, USA
- [5] S. Du, A. K. Saha, D. B. Johnson, "RMAC: A Routing-Enhanced Duty- Cycle MAC Protocol for Wireless Sensor Networks" in INFOCOM 2007.
- [6] ML Sichitiu, "Cross-layer scheduling for power efficiency in wireless sensor networks," in INFOCOM, 2004, pp. 1740–, 1750.
- [7] B. Deb, S. Bhatnagar, and B. Nath, "A Topology Discovery Algorithm for Sensor Networks with Applications to Network Management" Technical Report Technical Report DCS-TR-441, Department of Computer Science, Rutgers University, May 2001.
- [8] M. Liu and C. F. Hsin, "Network coverage using low duty-cycled sensors: Random and coordinated sleep algorithms," in IPSN, 2004
- [9] D. Tian and N. D. Georganas, "A Node Scheduling Scheme for Energy Conservation in Large Wireless Sensor Networks," in Wireless Communication Mobile Computing 2003; 3:271–290
- [10] W. Ye, J. Heidemann, and D. Estrin, "An Energy-Efficient MAC Protocol for Wireless sensor Networks," in Proc. IEEE. INFOCOM, Jun. 2002
- [11] F. Ye, G. Zhong, S. Lu, L. Zhang, "PEAS: A Robust Energy Conserving Protocol for Long-lived Sensor Networks," in Proceedings of the 23rd International Conference on Distributed Computing Systems (ICDCS'03)
- [12] J. H. Abawajy, S. Nahavandi and F. Al-Neyadi, "Sensor Node Activity Scheduling Approach," in IEEE, 2007 International Conference on Multimedia and Ubiquitous Engineering (MUE'07)
- [13] K. Akkaya, M. Younis, "A survey on Routing Protocols for Wireless Sensor Networks", Computer Networks (Elsevier) Journal, 2004